

Check-out counter lines

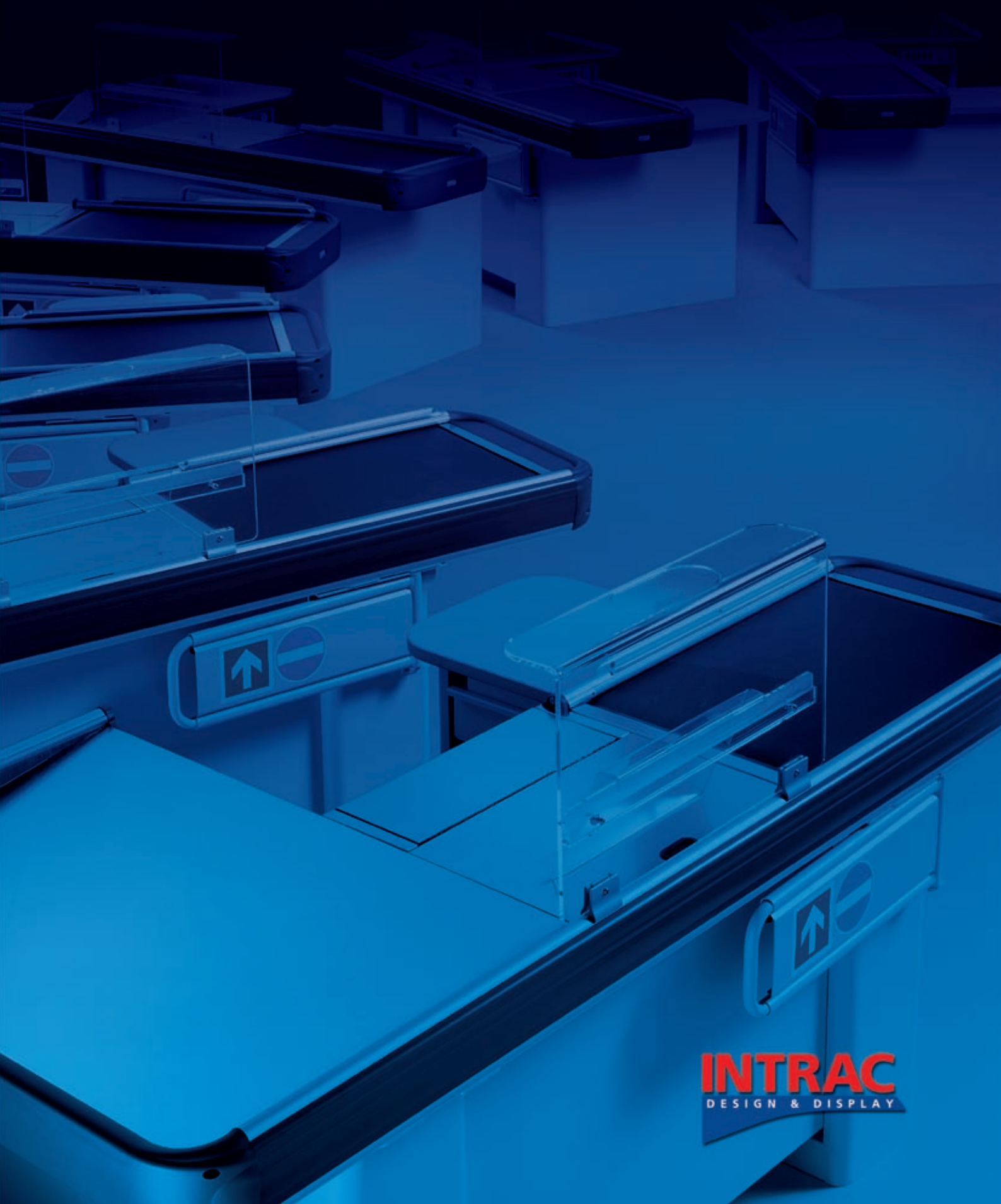

Check-out counter lines



Semplicity & Design for a new sale



concept



Una linea flessibile di mobili cassa statici e motorizzati, disponibili in una gamma di modelli adatti ad ogni superficie di vendita. Robustezza, accessori, facilità d'uso unite ad un design rigoroso e minimalista consentono alle casse EMV-ESV di adattarsi a creative soluzioni d'arredamento contemporaneo.

A flexible line of static and motorised check out counters, available in a wide range of models suitable for every size of store. Solidity, great range of accessories, easiness at use combined with a severe and minimalist design make the check out counters EMV-ESV the right answer for the most creative solutions of modern interior design.



Motore ad alta potenza di trascinamento e con raffreddamento ad olio. Nastro PVC antistatico e con doppia tela in poliestere (solo linea EMV).

Motor with high belt drive power and oil cooling. Antistatic PVC belt and with double polyester cloth (only for EMV line).



Quadro elettronico di comando alloggiato in posizione ergonomica (solo linea EMV).

Electric control panel placed in an ergonomic position (only for EMV line).



04

Check-out counter lines

Technical features and strong points



Frontale anteriore arrotondato in poliuretano morbido tipo antiurto, antiestinguente e antifumo (+/- RAL 7043).

Rear rounded panel made of soft, shock-proof, self-extinguishing, anti-smoke, soft polyurethane (+/- RAL 7043).



Struttura portante in alluminio anodizzato con protezione laterale in PVC rigido antiurto colore grigio (+/- RAL 7043)

Supporting structure in anodised aluminium with lateral bumper in shock-proof, rigid, grey PVC (+/- RAL 7043).



Piano lavoro/scanner in acciaio inox rigidizzato; l'impiego di questo materiale consente di coniugare l'aspetto estetico con quello funzionale.

Working top/scanner module made of stiffened stainless steel for stylish and functional purposes.



Piano in acciaio inox rigidizzato e rinforzato, realizzato con bordi arrotondati e senza giunzioni (solo linea ESV).

Stiffened, reinforced stainless steel shelf, forged with rounded edges without joints (only for ESV line).



Carenatura laterale coprente in acciaio verniciato, completa internamente di alloggiamento cavi elettrici.

Covering lateral trim made of painted steel, complete with housing for electrical cables.



Struttura portante in acciaio verniciato con angoli arrotondati.

Supporting structure made of painted steel and with rounded corners.



Vasca in acciaio inox rigidizzato e rinforzato, realizzata con bordi arrotondati e senza giunzioni.

Stiffened, reinforced stainless steel basin, forged with rounded edges without joints.



Frontale posteriore L 1060mm e paracolpi merce arrotondato in poliuretano morbido tipo antiurto, antistinguente e antifumo (+/- RAL 7043).

Rear panel L 1060mm and shock-absorbing buffer made of soft, shock-proof, self-extinguishing, anti-smoke, soft polyurethane (+/- RAL 7043).



Frontale posteriore L 530mm arrotondato in poliuretano morbido tipo antiurto, antistinguente e antifumo (+/- RAL 7043).

Rear rounded panel L 530mm made of soft, shock-proof, self-extinguishing, anti-smoke, soft polyurethane (+/- RAL 7043).



NSV

NSV EMV

Mod.	L (mm)	N (mm)	S (mm)	V (mm)
NSV 170	1700	740	370	590
NSV 200	2000	890	370	740
NSV 230	2300	1190	370	740
NSV 260	2600	1190	370	1040
NSV 290	2900	1490	370	1040

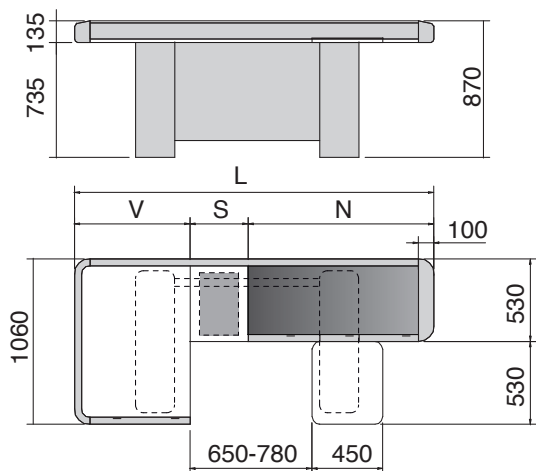

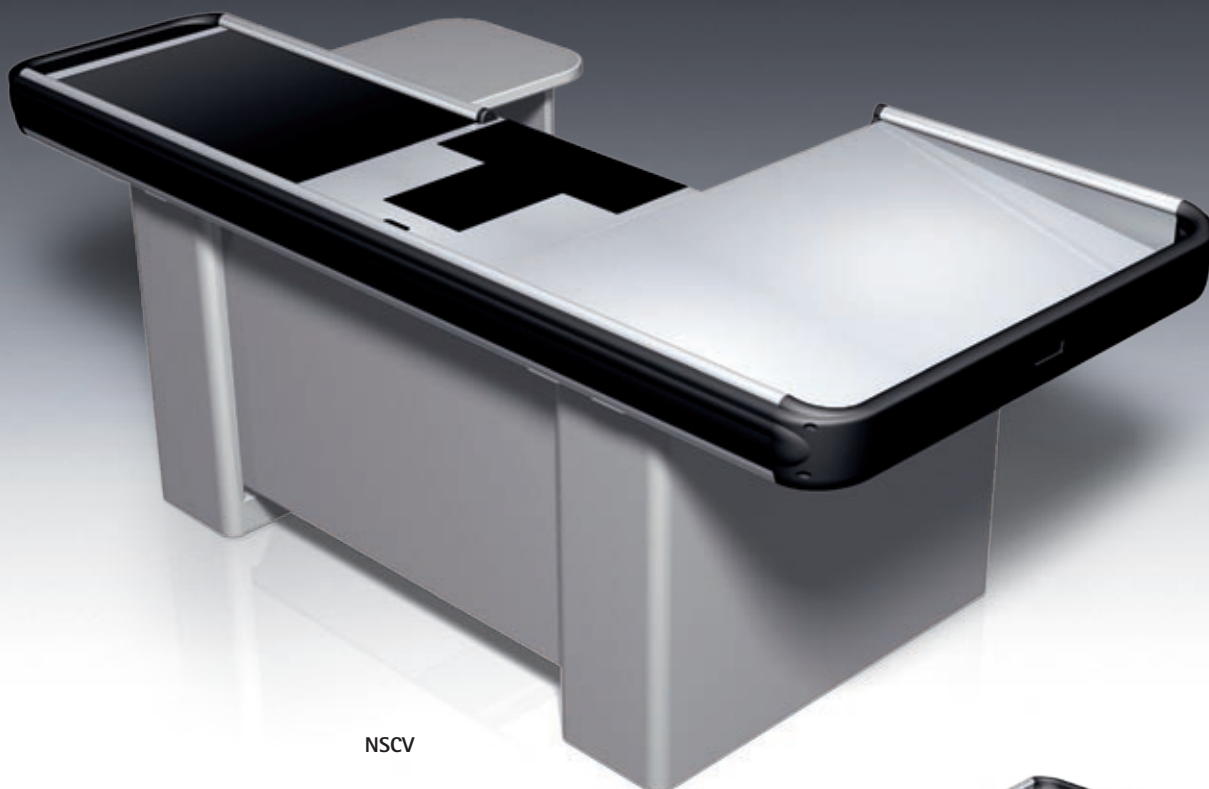

NSCV

NSCV EMV

Mod.	L (mm)	N (mm)	S (mm)	V (mm)
NSCV 185	1850	740	520	590
NSCV 215	2150	890	520	740
NSCV 245	2450	1190	520	740
NSCV 275	2750	1190	520	1040
NSCV 305	3050	1490	520	1040

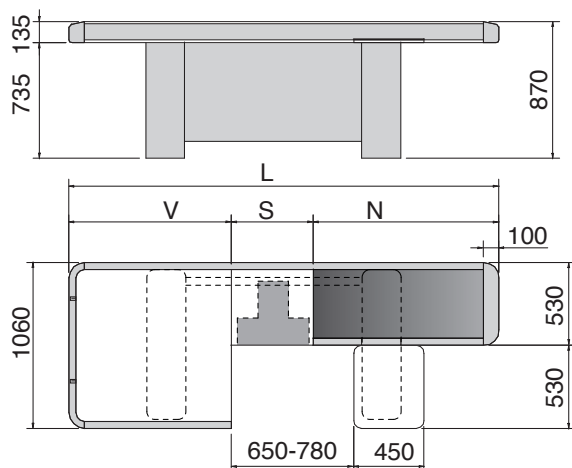



NSVD

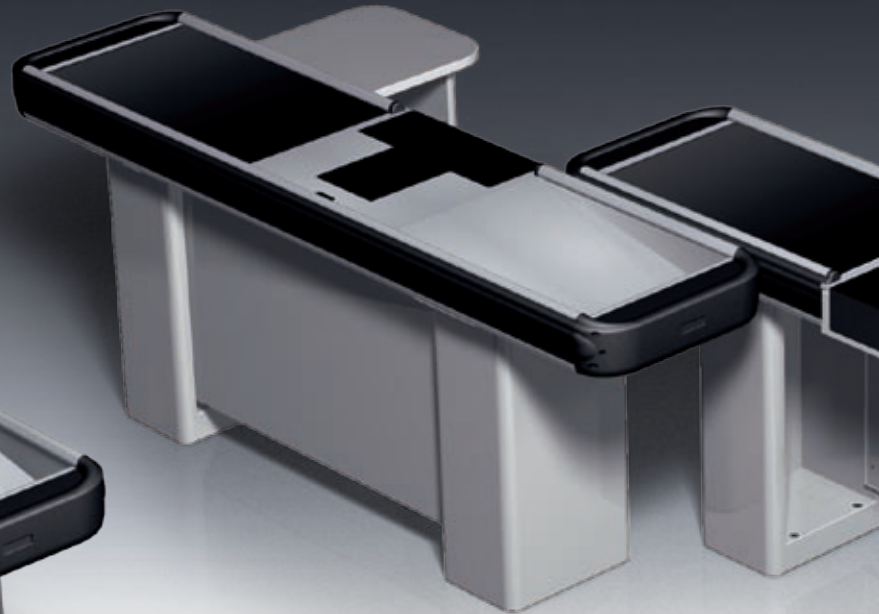

TANDEM

NSVD EMV

Mod.	L (mm)	N (mm)	S (mm)	V (mm)
NSVD 170	1700	740	370	590
NSVD 200	2000	890	370	740
NSVD 230	2300	1190	370	740
NSVD 260	2600	1190	370	1040
NSVD 290	2600	1490	370	1040

TANDEM EMV

Mod.	L (mm)	N (mm)	S (mm)	V (mm)
TANDEM 310	3100	740	520	590
TANDEM 355	3550	890	520	740
TANDEM 415	4150	1190	520	740

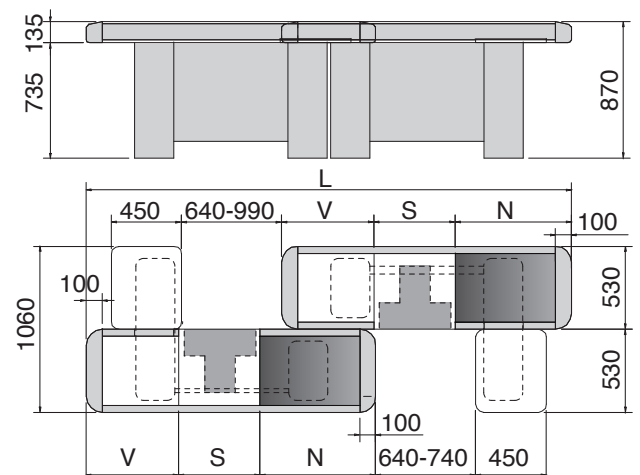
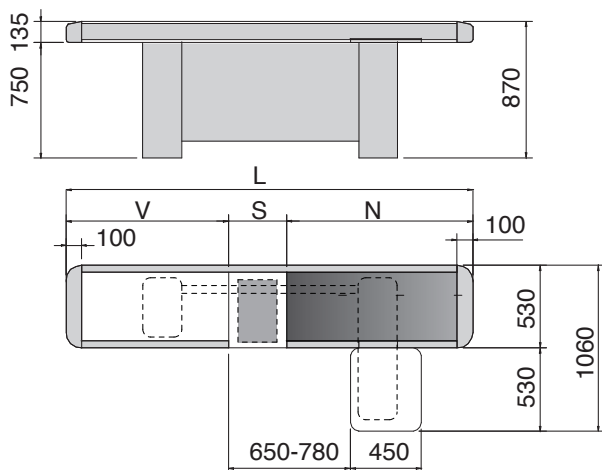

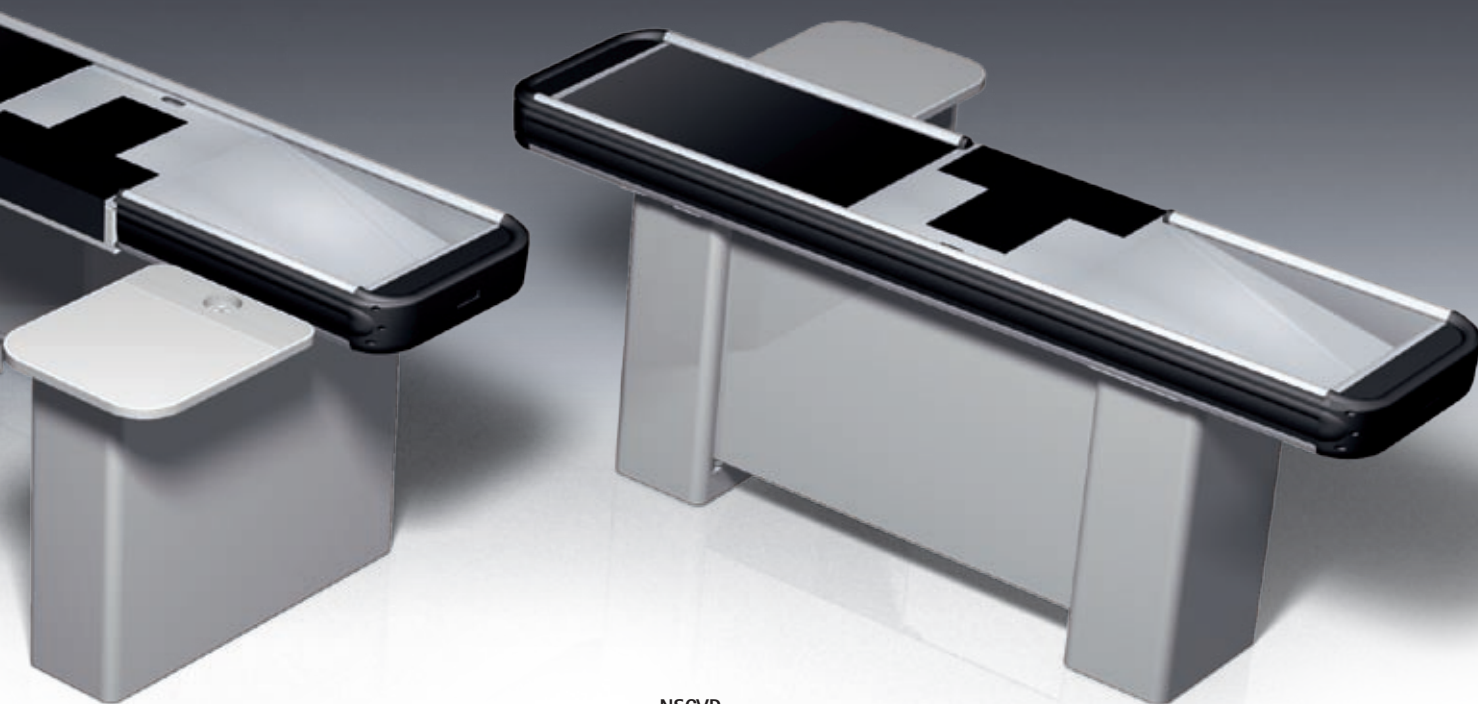

NSCVD

NSCVD EMV

Mod.	L (mm)	N (mm)	S (mm)	V (mm)
NSCVD 185	1850	740	520	590
NSCVD 215	2150	890	520	740
NSCVD 245	2450	1190	520	740
NSCVD 275	2750	1190	520	1040
NSCVD 305	3050	1490	520	1040

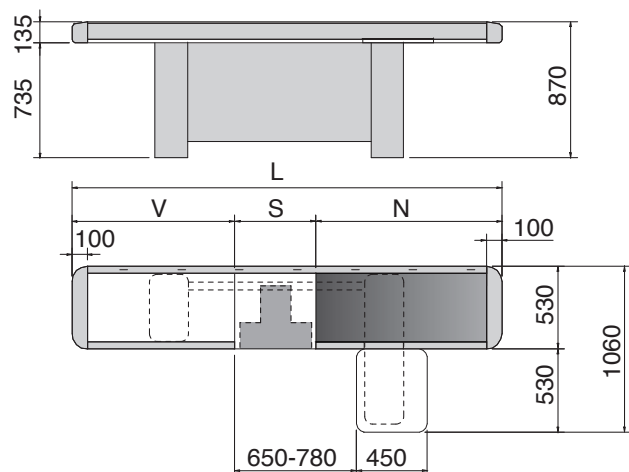
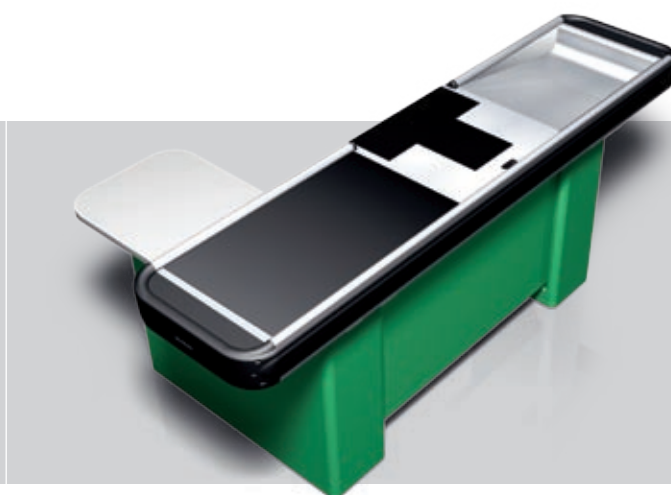

Two solutions for double satisfaction







PSV

PSV ESV

Mod.	L (mm)	P (mm)	S (mm)	V (mm)
PSV 170	1700	740	370	590
PSV 185	1850	740	370	740
PSV 200	2000	890	370	740

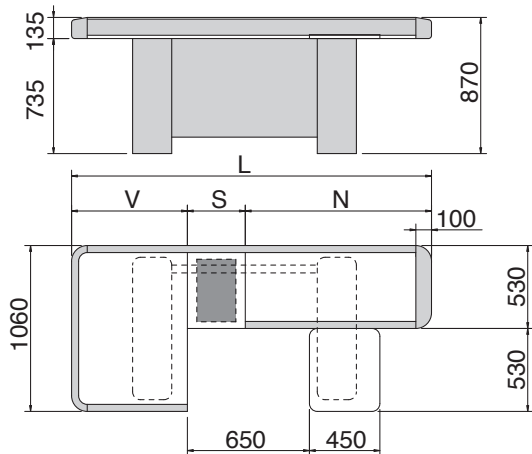



PSCV

PSCV ESV

Mod.	L (mm)	P (mm)	S (mm)	V (mm)
PSCV 185	1850	590	520	740
PSCV 215	2150	890	520	740

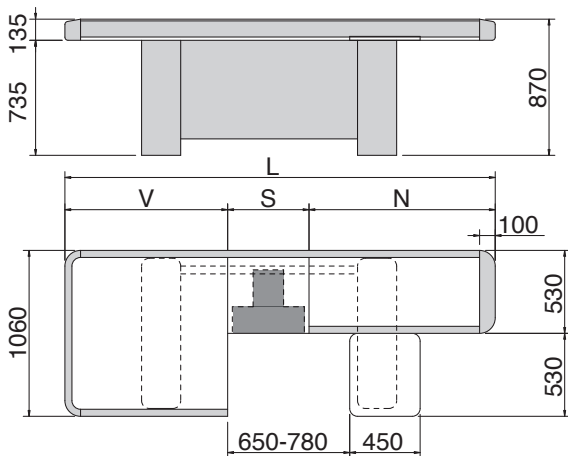



PSVD



TANDEM

PSVD ESV

Mod.	L (mm)	P (mm)	S (mm)	V (mm)
PSVD 125	1250	440	370	440
PSVD 155	1550	590	370	590
PSVD 170	1700	740	370	590
PSVD 200	2000	890	370	740

TANDEM ESV

Mod.	L (mm)	P (mm)	S (mm)	V (mm)
TANDEM 280	2800	590	520	590

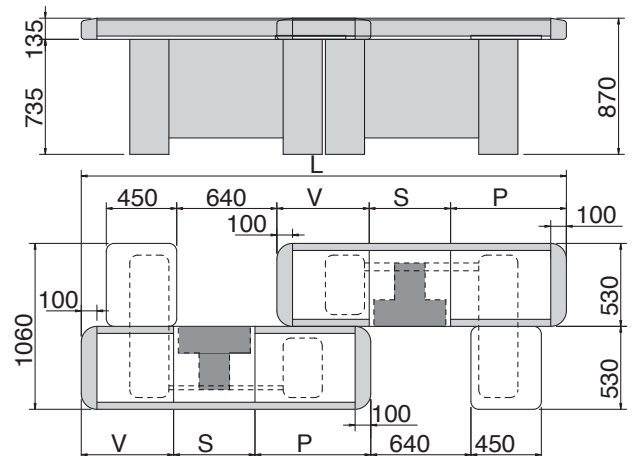
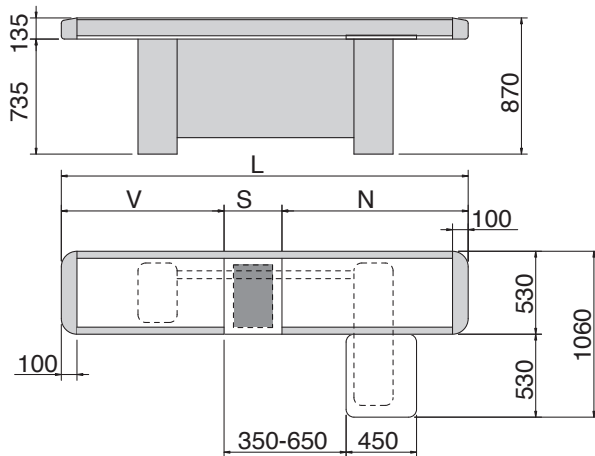

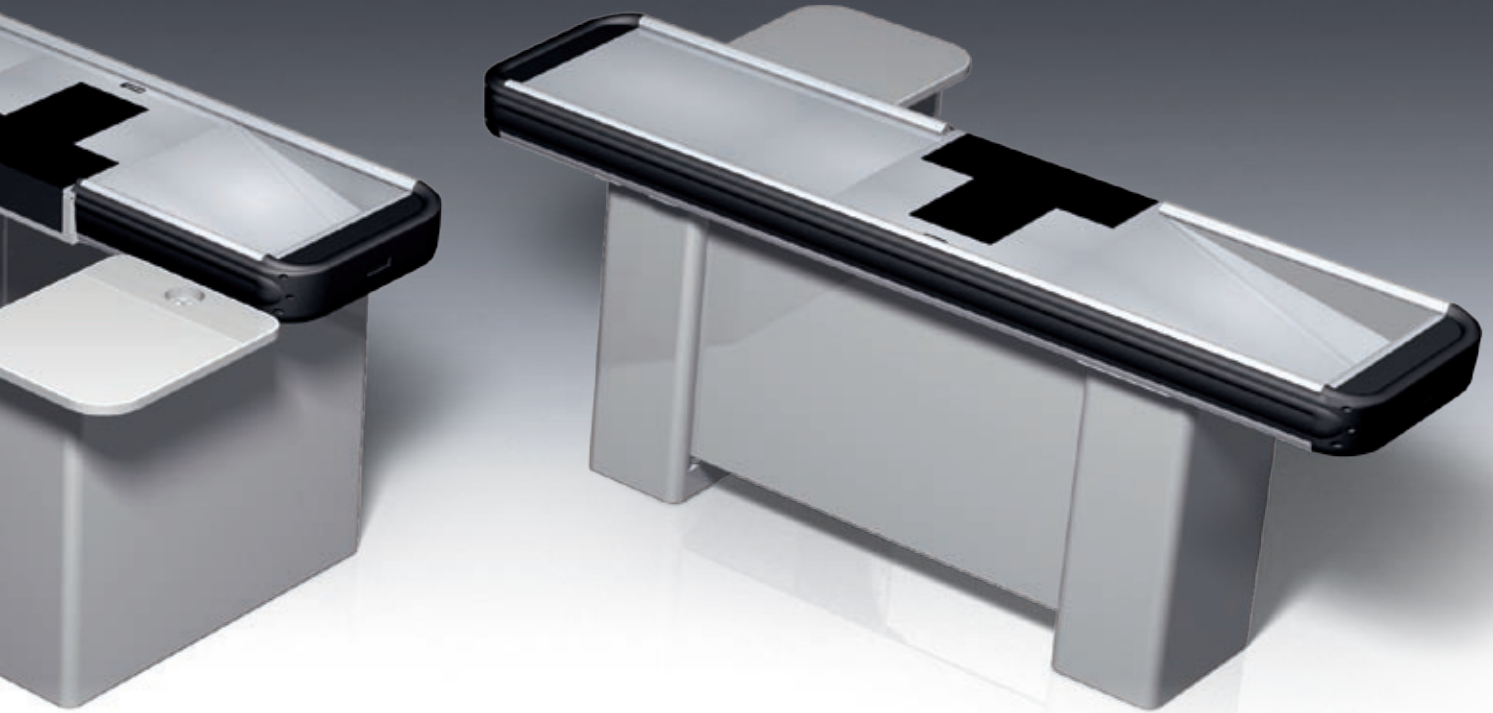

PSCVD

PSCVD ESV

Mod.	L (mm)	P (mm)	S (mm)	V (mm)
PSCVD 140	1400	440	520	440
PSCVD 170	1700	590	520	590
PSCVD 185	1850	740	520	590
PSCVD 215	2150	890	520	740

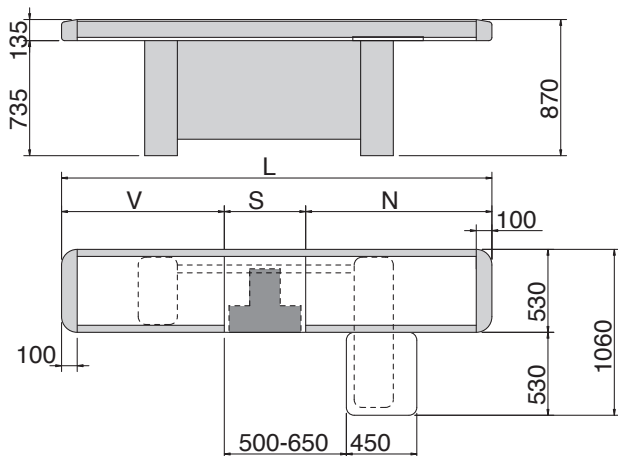

Check-out counter lines

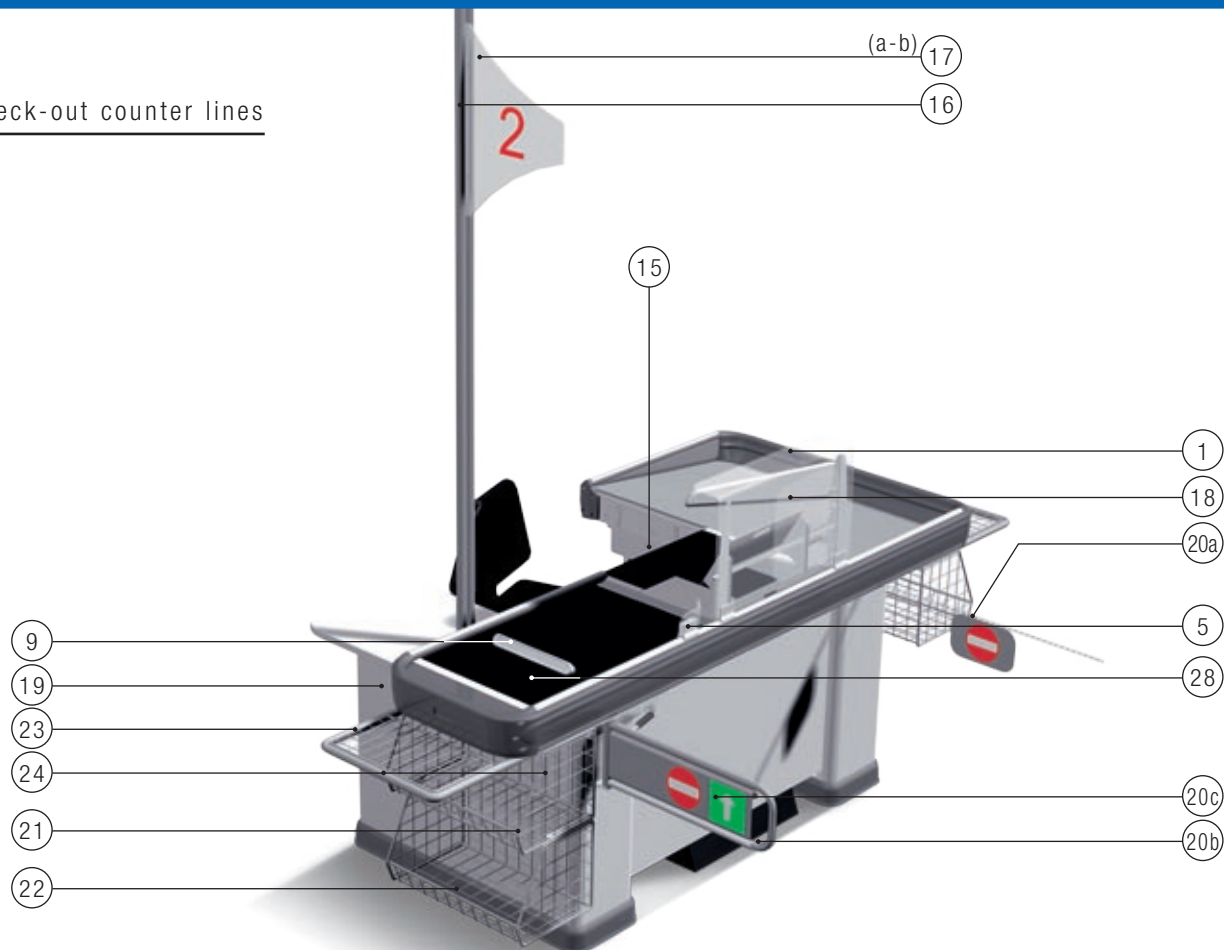

16

N°	Descrizione	EMV					
		NSV		NSCV		TANDEM	
		170	290 200	185	305 215	415 310	
1	Protezione scanner (Scanner protection set)	○	○	○	○	○	○
2	Portatastiera L. 350 (Keyboard support L. 350)	○	○	○	○	○	○
3	Attacco tastiera - p.ogg-pos (connection for keyboard, object holder, pos system)	○	○	○	○	○	○
4	Alloggiamento scanner e/o cassetto rendiresto (Scanner and/or cash drawer housing)	○	○	○	○	○	○
5	Deviamerice (Grocery deviator)	○	○	○	○	○	○
6	Cassetto rendiresto 12/24/36 V (Cash drawer 12/24/36 V)	○	○	○	○	○	○
7	Inserito cassetto rendiresto (Cash insert unit)	○	○	○	○	○	○
8	Spartimerce vasca (Grocery divider)	○	○	○	○	○	○
9	Assieme cliente successivo (Next customer set)	○	○	○	○	○	○
10	Profilo Paracqua (Water-proof profile)	○	○	○	○	○	○
11A	Piano fisso L. 1060 (Service fixed shelf L.1060)	○	○	○	○	○	○
11B	Piano fisso L.530 (Service fixed shelf L.530)	○	○	○	○	○	○
12	Fissaggio a pavimento (Floor fastening set)	○	○	○	○	○	○
13	Sgabello cassa con schienale (Check-out stool with back)	○	○	○	○	○	○
14	Cassetto servizio con chiave sottopiano (Below-shelf drawer with key)	○	○	○	○	○	○
15	Cassetto servizio con chiave sottovasca (Service drawer with key under basin)	○	○	○	○	○	○
16	Colonna passacavi H = 3m (3m cable column)	○	○	○	○	○	○
17A	Segnalatore numero cassa (Check-out number signal)	○	○	○	○	○	○
17B	Segnalatore cassa aperta illuminato (Check-out open light)	○	○	○	○	○	○
18	Lente grandangolare (Wide-angle lens)	○	○	○	○	○	○
19	Prese ausiliarie (Auxiliary jack set)	○	○	○	○	○	○
20A	Chiusura passaggio carrello catena in plastica (Plastic chain for trolley blocking device)	○	○	○	○	○	○
20B	Chiusura passaggio carrello (Trolley blocking device)	○	○	○	○	○	○
20C	Etichetta uscita sicurezza (Emergency exit label)	○	○	○	○	○	○
21	Portasacchetti anteriore 1 livello (1-level front bag-holder)	○	○	○	○	○	○
22	Portasacchetti anteriore 2 livello (2-level front bag-holder)	○	○	○	○	○	○
23	Poggiacesti anteriore (Front basket rest)	○	○	○	○	○	S1
24	Poggia + porta sacchetti anteriore 1 livello (1-level front bag rest + holder)	○	○	○	○	○	S1
25	Portasacchetti posteriore (Rear bag holder)	○	○	○	○	○	○
26	Poggiasacchetti posteriore (Rear bag rest)	○	○	○	○	○	S2
27	Poggia + porta sacchetti posteriore singolo (Rear bag rest + holder)	○	○	○	○	○	S2
28	Raccoglibriciole (Crumb collector)	○	○	○	○	○	○
29	Pedana regolab.+allogg. pedale (Adj. footboard with pedal housing)	○	○	○	○	○	○
30	Portaoggetti L.150 (Object holder L. 150)	○	○	○	○	○	○

Legenda EMV (EMV Abbreviations)

○ Disponibile (Available)

S1 Disponibile cassa tandem anteriore (For TANDEM check-out available on the front check-out)

S2 Disponibile cassa tandem posteriore (For TANDEM check-out available on the rear check-out)

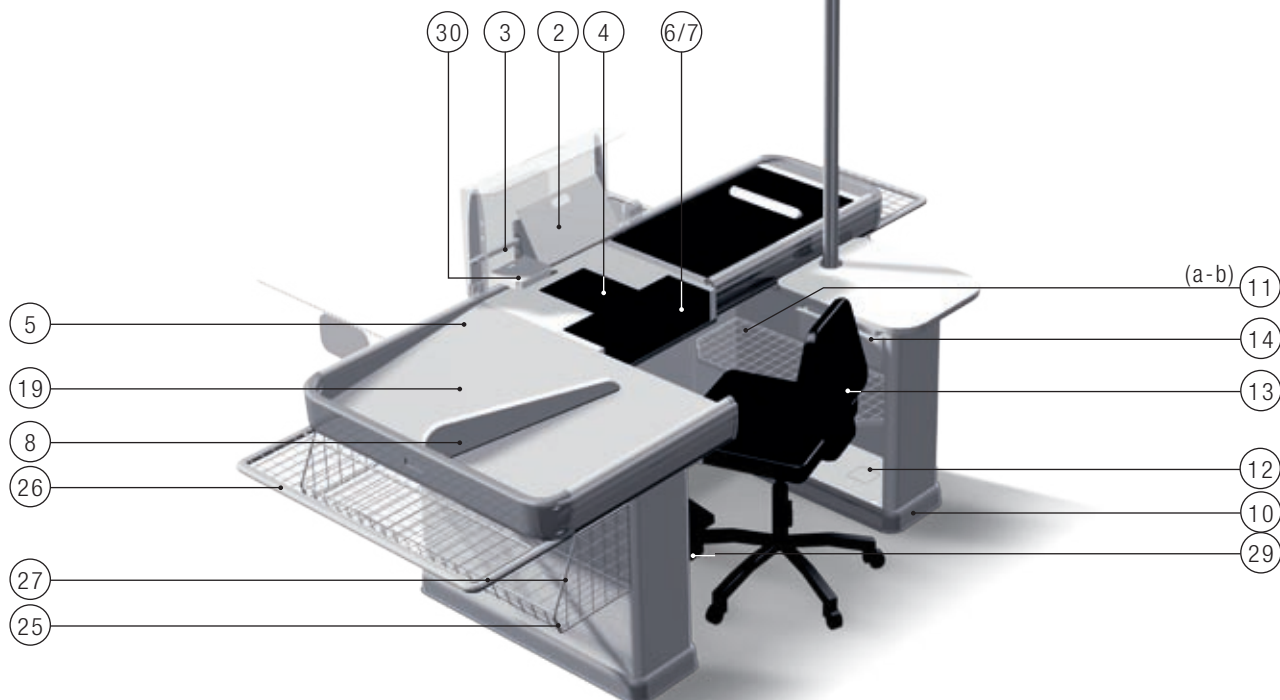

				ESV										
NSVD		NSCVD		PSV			PSCV		TANDEM	PSVD			PSCVD	
170	290 200	305 185	185 170	200	185	215	280	125	155	200 170	140	215 170		
<input type="checkbox"/>	<input type="checkbox"/>	<input type="checkbox"/>	<input type="checkbox"/>	<input type="checkbox"/>	<input type="checkbox"/>	<input type="checkbox"/>	<input type="checkbox"/>	<input type="checkbox"/>	<input type="checkbox"/>	<input type="checkbox"/>	<input type="checkbox"/>	<input type="checkbox"/>	<input type="checkbox"/>	<input type="checkbox"/>
<input type="checkbox"/>	<input type="checkbox"/>	<input type="checkbox"/>	<input type="checkbox"/>	<input type="checkbox"/>	<input type="checkbox"/>	<input type="checkbox"/>	<input type="checkbox"/>	<input type="checkbox"/>	<input type="checkbox"/>	<input type="checkbox"/>	<input type="checkbox"/>	<input type="checkbox"/>	<input type="checkbox"/>	<input type="checkbox"/>
<input type="checkbox"/>	<input type="checkbox"/>	<input type="checkbox"/>	<input type="checkbox"/>	<input type="checkbox"/>	<input type="checkbox"/>	<input type="checkbox"/>	<input type="checkbox"/>	<input type="checkbox"/>	<input type="checkbox"/>	<input type="checkbox"/>	<input type="checkbox"/>	<input type="checkbox"/>	<input type="checkbox"/>	<input type="checkbox"/>
<input type="checkbox"/>	<input type="checkbox"/>	<input type="checkbox"/>	<input type="checkbox"/>	<input type="checkbox"/>	<input type="checkbox"/>	<input type="checkbox"/>	<input type="checkbox"/>	<input type="checkbox"/>	<input type="checkbox"/>	<input type="checkbox"/>	<input type="checkbox"/>	<input type="checkbox"/>	<input type="checkbox"/>	<input type="checkbox"/>
<input type="checkbox"/>	<input type="checkbox"/>	<input type="checkbox"/>	<input type="checkbox"/>	<input type="checkbox"/>	<input type="checkbox"/>	<input type="checkbox"/>	<input type="checkbox"/>	<input type="checkbox"/>	<input type="checkbox"/>	<input type="checkbox"/>	<input type="checkbox"/>	<input type="checkbox"/>	<input type="checkbox"/>	<input type="checkbox"/>
<input type="checkbox"/>	<input type="checkbox"/>	<input type="checkbox"/>	<input type="checkbox"/>	<input type="checkbox"/>	<input type="checkbox"/>	<input type="checkbox"/>	<input type="checkbox"/>	<input type="checkbox"/>	<input type="checkbox"/>	<input type="checkbox"/>	<input type="checkbox"/>	<input type="checkbox"/>	<input type="checkbox"/>	<input type="checkbox"/>
<input type="checkbox"/>	<input type="checkbox"/>	<input type="checkbox"/>	<input type="checkbox"/>	<input type="checkbox"/>	<input type="checkbox"/>	<input type="checkbox"/>	<input type="checkbox"/>	<input type="checkbox"/>	<input type="checkbox"/>	<input type="checkbox"/>	<input type="checkbox"/>	<input type="checkbox"/>	<input type="checkbox"/>	<input type="checkbox"/>
<input type="checkbox"/>	<input type="checkbox"/>	<input type="checkbox"/>	<input type="checkbox"/>	<input type="checkbox"/>	<input type="checkbox"/>	<input type="checkbox"/>	<input type="checkbox"/>	<input type="checkbox"/>	<input type="checkbox"/>	<input type="checkbox"/>	<input type="checkbox"/>	<input type="checkbox"/>	<input type="checkbox"/>	<input type="checkbox"/>
<input type="checkbox"/>	<input type="checkbox"/>	<input type="checkbox"/>	<input type="checkbox"/>	<input type="checkbox"/>	<input type="checkbox"/>	<input type="checkbox"/>	<input type="checkbox"/>	<input type="checkbox"/>	<input type="checkbox"/>	<input type="checkbox"/>	<input type="checkbox"/>	<input type="checkbox"/>	<input type="checkbox"/>	<input type="checkbox"/>
<input type="checkbox"/>	<input type="checkbox"/>	<input type="checkbox"/>	<input type="checkbox"/>	<input type="checkbox"/>	<input type="checkbox"/>	<input type="checkbox"/>	<input type="checkbox"/>	<input type="checkbox"/>	<input type="checkbox"/>	<input type="checkbox"/>	<input type="checkbox"/>	<input type="checkbox"/>	<input type="checkbox"/>	<input type="checkbox"/>
<input type="checkbox"/>	<input type="checkbox"/>	<input type="checkbox"/>	<input type="checkbox"/>	<input type="checkbox"/>	<input type="checkbox"/>	<input type="checkbox"/>	<input type="checkbox"/>	<input type="checkbox"/>	<input type="checkbox"/>	<input type="checkbox"/>	<input type="checkbox"/>	<input type="checkbox"/>	<input type="checkbox"/>	<input type="checkbox"/>
<input type="checkbox"/>	<input type="checkbox"/>	<input type="checkbox"/>	<input type="checkbox"/>	<input type="checkbox"/>	<input type="checkbox"/>	<input type="checkbox"/>	<input type="checkbox"/>	<input type="checkbox"/>	<input type="checkbox"/>	<input type="checkbox"/>	<input type="checkbox"/>	<input type="checkbox"/>	<input type="checkbox"/>	<input type="checkbox"/>
<input type="checkbox"/>	<input type="checkbox"/>	<input type="checkbox"/>	<input type="checkbox"/>	<input type="checkbox"/>	<input type="checkbox"/>	<input type="checkbox"/>	<input type="checkbox"/>	<input type="checkbox"/>	<input type="checkbox"/>	<input type="checkbox"/>	<input type="checkbox"/>	<input type="checkbox"/>	<input type="checkbox"/>	<input type="checkbox"/>
<input type="checkbox"/>	<input type="checkbox"/>	<input type="checkbox"/>	<input type="checkbox"/>	<input type="checkbox"/>	<input type="checkbox"/>	<input type="checkbox"/>	<input type="checkbox"/>	<input type="checkbox"/>	<input type="checkbox"/>	<input type="checkbox"/>	<input type="checkbox"/>	<input type="checkbox"/>	<input type="checkbox"/>	<input type="checkbox"/>
<input type="checkbox"/>	<input type="checkbox"/>	<input type="checkbox"/>	<input type="checkbox"/>	<input type="checkbox"/>	<input type="checkbox"/>	<input type="checkbox"/>	<input type="checkbox"/>	<input type="checkbox"/>	<input type="checkbox"/>	<input type="checkbox"/>	<input type="checkbox"/>	<input type="checkbox"/>	<input type="checkbox"/>	<input type="checkbox"/>
<input type="checkbox"/>	<input type="checkbox"/>	<input type="checkbox"/>	<input type="checkbox"/>	<input type="checkbox"/>	<input type="checkbox"/>	<input type="checkbox"/>	<input type="checkbox"/>	<input type="checkbox"/>	<input type="checkbox"/>	<input type="checkbox"/>	<input type="checkbox"/>	<input type="checkbox"/>	<input type="checkbox"/>	<input type="checkbox"/>
<input type="checkbox"/>	<input type="checkbox"/>	<input type="checkbox"/>	<input type="checkbox"/>	<input type="checkbox"/>	<input type="checkbox"/>	<input type="checkbox"/>	<input type="checkbox"/>	<input type="checkbox"/>	<input type="checkbox"/>	<input type="checkbox"/>	<input type="checkbox"/>	<input type="checkbox"/>	<input type="checkbox"/>	<input type="checkbox"/>
<input type="checkbox"/>	<input type="checkbox"/>	<input type="checkbox"/>	<input type="checkbox"/>	<input type="checkbox"/>	<input type="checkbox"/>	<input type="checkbox"/>	<input type="checkbox"/>	<input type="checkbox"/>	<input type="checkbox"/>	<input type="checkbox"/>	<input type="checkbox"/>	<input type="checkbox"/>	<input type="checkbox"/>	<input type="checkbox"/>
<input type="checkbox"/>	<input type="checkbox"/>	<input type="checkbox"/>	<input type="checkbox"/>	<input type="checkbox"/>	<input type="checkbox"/>	<input type="checkbox"/>	<input type="checkbox"/>	<input type="checkbox"/>	<input type="checkbox"/>	<input type="checkbox"/>	<input type="checkbox"/>	<input type="checkbox"/>	<input type="checkbox"/>	<input type="checkbox"/>
<input type="checkbox"/>	<input type="checkbox"/>	<input type="checkbox"/>	<input type="checkbox"/>	<input type="checkbox"/>	<input type="checkbox"/>	<input type="checkbox"/>	<input type="checkbox"/>	<input type="checkbox"/>	<input type="checkbox"/>	<input type="checkbox"/>	<input type="checkbox"/>	<input type="checkbox"/>	<input type="checkbox"/>	<input type="checkbox"/>
<input type="checkbox"/>	<input type="checkbox"/>	<input type="checkbox"/>	<input type="checkbox"/>	<input type="checkbox"/>	<input type="checkbox"/>	<input type="checkbox"/>	<input type="checkbox"/>	<input type="checkbox"/>	<input type="checkbox"/>	<input type="checkbox"/>	<input type="checkbox"/>	<input type="checkbox"/>	<input type="checkbox"/>	<input type="checkbox"/>
<input type="checkbox"/>	<input type="checkbox"/>	<input type="checkbox"/>	<input type="checkbox"/>	<input type="checkbox"/>	<input type="checkbox"/>	<input type="checkbox"/>	<input type="checkbox"/>	<input type="checkbox"/>	<input type="checkbox"/>	<input type="checkbox"/>	<input type="checkbox"/>	<input type="checkbox"/>	<input type="checkbox"/>	<input type="checkbox"/>
<input type="checkbox"/>	<input type="checkbox"/>	<input type="checkbox"/>	<input type="checkbox"/>	<input type="checkbox"/>	<input type="checkbox"/>	<input type="checkbox"/>	<input type="checkbox"/>	<input type="checkbox"/>	<input type="checkbox"/>	<input type="checkbox"/>	<input type="checkbox"/>	<input type="checkbox"/>	<input type="checkbox"/>	<input type="checkbox"/>
<input type="checkbox"/>	<input type="checkbox"/>	<input type="checkbox"/>	<input type="checkbox"/>	<input type="checkbox"/>	<input type="checkbox"/>	<input type="checkbox"/>	<input type="checkbox"/>	<input type="checkbox"/>	<input type="checkbox"/>	<input type="checkbox"/>	<input type="checkbox"/>	<input type="checkbox"/>	<input type="checkbox"/>	<input type="checkbox"/>
<input type="checkbox"/>	<input type="checkbox"/>	<input type="checkbox"/>	<input type="checkbox"/>	<input type="checkbox"/>	<input type="checkbox"/>	<input type="checkbox"/>	<input type="checkbox"/>	<input type="checkbox"/>	<input type="checkbox"/>	<input type="checkbox"/>	<input type="checkbox"/>	<input type="checkbox"/>	<input type="checkbox"/>	<input type="checkbox"/>
<input type="checkbox"/>	<input type="checkbox"/>	<input type="checkbox"/>	<input type="checkbox"/>	<input type="checkbox"/>	<input type="checkbox"/>	<input type="checkbox"/>	<input type="checkbox"/>	<input type="checkbox"/>	<input type="checkbox"/>	<input type="checkbox"/>	<input type="checkbox"/>	<input type="checkbox"/>	<input type="checkbox"/>	<input type="checkbox"/>
<input type="checkbox"/>	<input type="checkbox"/>	<input type="checkbox"/>	<input type="checkbox"/>	<input type="checkbox"/>	<input type="checkbox"/>	<input type="checkbox"/>	<input type="checkbox"/>	<input type="checkbox"/>	<input type="checkbox"/>	<input type="checkbox"/>	<input type="checkbox"/>	<input type="checkbox"/>	<input type="checkbox"/>	<input type="checkbox"/>
<input type="checkbox"/>	<input type="checkbox"/>	<input type="checkbox"/>	<input type="checkbox"/>	<input type="checkbox"/>	<input type="checkbox"/>	<input type="checkbox"/>	<input type="checkbox"/>	<input type="checkbox"/>	<input type="checkbox"/>	<input type="checkbox"/>	<input type="checkbox"/>	<input type="checkbox"/>	<input type="checkbox"/>	<input type="checkbox"/>
<input type="checkbox"/>	<input type="checkbox"/>	<input type="checkbox"/>	<input type="checkbox"/>	<input type="checkbox"/>	<input type="checkbox"/>	<input type="checkbox"/>	<input type="checkbox"/>	<input type="checkbox"/>	<input type="checkbox"/>	<input type="checkbox"/>	<input type="checkbox"/>	<input type="checkbox"/>	<input type="checkbox"/>	<input type="checkbox"/>
<input type="checkbox"/>	<input type="checkbox"/>	<input type="checkbox"/>	<input type="checkbox"/>	<input type="checkbox"/>	<input type="checkbox"/>	<input type="checkbox"/>	<input type="checkbox"/>	<input type="checkbox"/>	<input type="checkbox"/>	<input type="checkbox"/>	<input type="checkbox"/>	<input type="checkbox"/>	<input type="checkbox"/>	<input type="checkbox"/>
<input type="checkbox"/>	<input type="checkbox"/>	<input type="checkbox"/>	<input type="checkbox"/>	<input type="checkbox"/>	<input type="checkbox"/>	<input type="checkbox"/>	<input type="checkbox"/>	<input type="checkbox"/>	<input type="checkbox"/>	<input type="checkbox"/>	<input type="checkbox"/>	<input type="checkbox"/>	<input type="checkbox"/>	<input type="checkbox"/>
<input type="checkbox"/>	<input type="checkbox"/>	<input type="checkbox"/>	<input type="checkbox"/>	<input type="checkbox"/>	<input type="checkbox"/>	<input type="checkbox"/>	<input type="checkbox"/>	<input type="checkbox"/>	<input type="checkbox"/>	<input type="checkbox"/>	<input type="checkbox"/>	<input type="checkbox"/>	<input type="checkbox"/>	<input type="checkbox"/>
<input type="checkbox"/>	<input type="checkbox"/>	<input type="checkbox"/>	<input type="checkbox"/>	<input type="checkbox"/>	<input type="checkbox"/>	<input type="checkbox"/>	<input type="checkbox"/>	<input type="checkbox"/>	<input type="checkbox"/>	<input type="checkbox"/>	<input type="checkbox"/>	<input type="checkbox"/>	<input type="checkbox"/>	<input type="checkbox"/>
<input type="checkbox"/>	<input type="checkbox"/>	<input type="checkbox"/>	<input type="checkbox"/>	<input type="checkbox"/>	<input type="checkbox"/>	<input type="checkbox"/>	<input type="checkbox"/>	<input type="checkbox"/>	<input type="checkbox"/>	<input type="checkbox"/>	<input type="checkbox"/>	<input type="checkbox"/>	<input type="checkbox"/>	<input type="checkbox"/>
<input type="checkbox"/>	<input type="checkbox"/>	<input type="checkbox"/>	<input type="checkbox"/>	<input type="checkbox"/>	<input type="checkbox"/>	<input type="checkbox"/>	<input type="checkbox"/>	<input type="checkbox"/>	<input type="checkbox"/>	<input type="checkbox"/>	<input type="checkbox"/>	<input type="checkbox"/>	<input type="checkbox"/>	<input type="checkbox"/>
<input type="checkbox"/>	<input type="checkbox"/>	<input type="checkbox"/>	<input type="checkbox"/>	<input type="checkbox"/>	<input type="checkbox"/>	<input type="checkbox"/>	<input type="checkbox"/>	<input type="checkbox"/>	<input type="checkbox"/>	<input type="checkbox"/>	<input type="checkbox"/>	<input type="checkbox"/>	<input type="checkbox"/>	<input type="checkbox"/>
<input type="checkbox"/>	<input type="checkbox"/>	<input type="checkbox"/>	<input type="checkbox"/>	<input type="checkbox"/>	<input type="checkbox"/>	<input type="checkbox"/>	<input type="checkbox"/>	<input type="checkbox"/>	<input type="checkbox"/>	<input type="checkbox"/>	<input type="checkbox"/>	<input type="checkbox"/>	<input type="checkbox"/>	<input type="checkbox"/>
<input type="checkbox"/>	<input type="checkbox"/>	<input type="checkbox"/>	<input type="checkbox"/>	<input type="checkbox"/>	<input type="checkbox"/>	<input type="checkbox"/>	<input type="checkbox"/>	<input type="checkbox"/>	<input type="checkbox"/>	<input type="checkbox"/>	<input type="checkbox"/>	<input type="checkbox"/>	<input type="checkbox"/>	<input type="checkbox"/>
<input type="checkbox"/>	<input type="checkbox"/>	<input type="checkbox"/>	<input type="checkbox"/>	<input type="checkbox"/>	<input type="checkbox"/>	<input type="checkbox"/>	<input type="checkbox"/>	<input type="checkbox"/>	<input type="checkbox"/>	<input type="checkbox"/>	<input type="checkbox"/>	<input type="checkbox"/>	<input type="checkbox"/>	<input type="checkbox"/>
<input type="checkbox"/>	<input type="checkbox"/>	<input type="checkbox"/>	<input type="checkbox"/>	<input type="checkbox"/>	<input type="checkbox"/>	<input type="checkbox"/>	<input type="checkbox"/>	<input type="checkbox"/>	<input type="checkbox"/>	<input type="checkbox"/>	<input type="checkbox"/>	<input type="checkbox"/>	<input type="checkbox"/>	<input type="checkbox"/>
<input type="checkbox"/>	<input type="checkbox"/>	<input type="checkbox"/>	<input type="checkbox"/>	<input type="checkbox"/>	<input type="checkbox"/>	<input type="checkbox"/>	<input type="checkbox"/>	<input type="checkbox"/>	<input type="checkbox"/>	<input type="checkbox"/>	<input type="checkbox"/>	<input type="checkbox"/>	<input type="checkbox"/>	<input type="checkbox"/>
<input type="checkbox"/>	<input type="checkbox"/>	<input type="checkbox"/>	<input type="checkbox"/>	<input type="checkbox"/>	<input type="checkbox"/>	<input type="checkbox"/>	<input type="checkbox"/>	<input type="checkbox"/>	<input type="checkbox"/>	<input type="checkbox"/>	<input type="checkbox"/>	<input type="checkbox"/>	<input type="checkbox"/>	<input type="checkbox"/>
<input type="checkbox"/>	<input type="checkbox"/>	<input type="checkbox"/>	<input type="checkbox"/>	<input type="checkbox"/>	<input type="checkbox"/>	<input type="checkbox"/>	<input type="checkbox"/>	<input type="checkbox"/>	<input type="checkbox"/>	<input type="checkbox"/>	<input type="checkbox"/>	<input type="checkbox"/>	<input type="checkbox"/>	<input type="checkbox"/>
<input type="checkbox"/>	<input type="checkbox"/>	<input type="checkbox"/>	<input type="checkbox"/>	<input type="checkbox"/>	<input type="checkbox"/>	<input type="checkbox"/>	<input type="checkbox"/>	<input type="checkbox"/>	<input type="checkbox"/>	<input type="checkbox"/>	<input type="checkbox"/>	<input type="checkbox"/>	<input type="checkbox"/>	<input type="checkbox"/>
<input type="checkbox"/>	<input type="checkbox"/>	<input type="checkbox"/>	<input type="checkbox"/>	<input type="checkbox"/>	<input type="checkbox"/>	<input type="checkbox"/>	<input type="checkbox"/>	<input type="checkbox"/>	<input type="checkbox"/>	<input type="checkbox"/>	<input type="checkbox"/>	<input type="checkbox"/>	<input type="checkbox"/>	<input type="checkbox"/>
<input type="checkbox"/>	<input type="checkbox"/>	<input type="checkbox"/>	<input type="checkbox"/>	<input type="checkbox"/>	<input type="checkbox"/>	<input type="checkbox"/>	<input type="checkbox"/>	<input type="checkbox"/>	<input type="checkbox"/>	<input type="checkbox"/>	<input type="checkbox"/>	<input type="checkbox"/>	<input type="checkbox"/>	<input type="checkbox"/>
<input type="checkbox"/>	<input type="checkbox"/>	<input type="checkbox"/>	<input type="checkbox"/>	<input type="checkbox"/>	<input type="checkbox"/>	<input type="checkbox"/>	<input type="checkbox"/>	<input type="checkbox"/>	<input type="checkbox"/>	<input type="checkbox"/>	<input type="checkbox"/>	<input type="checkbox"/>	<input type="checkbox"/>	<input type="checkbox"/>
<input type="checkbox"/>	<input type="checkbox"/>	<input type="checkbox"/>	<input type="checkbox"/>	<input type="checkbox"/>	<input type="checkbox"/>	<input type="checkbox"/>	<input type="checkbox"/>	<input type="checkbox"/>	<input type="checkbox"/>	<input type="checkbox"/>	<input type="checkbox"/>	<input type="checkbox"/>	<input type="checkbox"/>	<input type="checkbox"/>
<input type="checkbox"/>	<input type="checkbox"/>	<input type="checkbox"/>	<input type="checkbox"/>	<input type="checkbox"/>	<input type="checkbox"/>	<input type="checkbox"/>	<input type="checkbox"/>	<input type="checkbox"/>	<input type="checkbox"/>	<input type="checkbox"/>	<input type="checkbox"/>	<input type="checkbox"/>	<input type="checkbox"/>	<input type="checkbox"/>
<input type="checkbox"/>	<input type="checkbox"/>	<input type="checkbox"/>	<input type="checkbox"/>	<input type="checkbox"/>	<input type="checkbox"/>	<input type="checkbox"/>	<input type="checkbox"/>	<input type="checkbox"/>	<input type="checkbox"/>	<input type="checkbox"/>	<input type="checkbox"/>	<input type="checkbox"/>	<input type="checkbox"/>	<input type="checkbox"/>
<input type="checkbox"/>	<input type="checkbox"/>	<input type="checkbox"/>	<input type="checkbox"/>	<input type="checkbox"/>	<input type="checkbox"/>	<input type="checkbox"/>	<input type="checkbox"/>	<input type="checkbox"/>	<input type="checkbox"/>	<input type="checkbox"/>	<input type="checkbox"/>	<input type="checkbox"/>	<input type="checkbox"/>	<input type="checkbox"/>

Legenda ESV (ESV Abbreviations)
 ○ Disponibile (Available)
 S1 Disponibile cassa tandem anteriore (For TANDEM check-out available on the front check-out)
 S2 Disponibile cassa tandem posteriore (For TANDEM check-out available on the rear check-out)

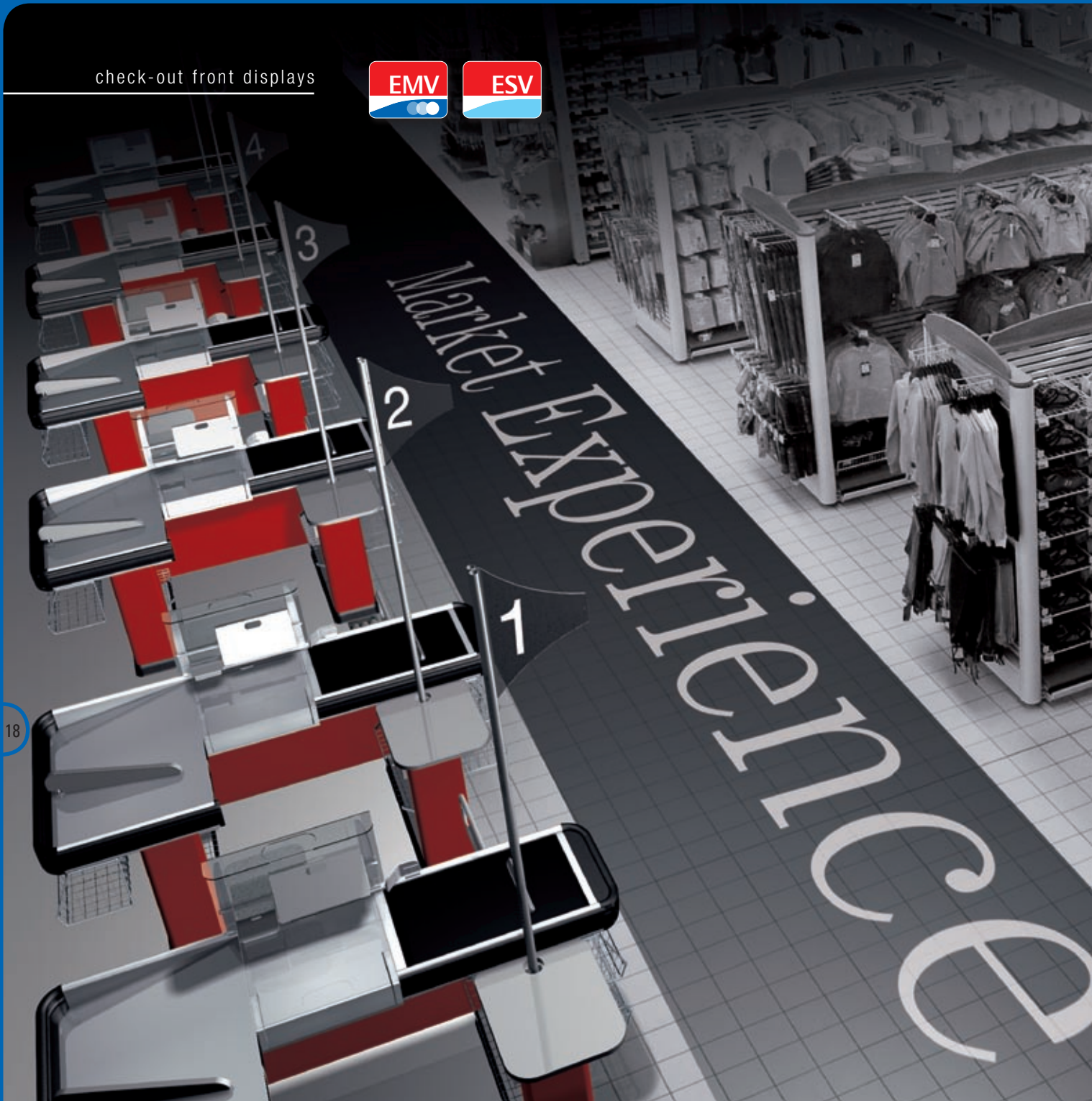

FLF

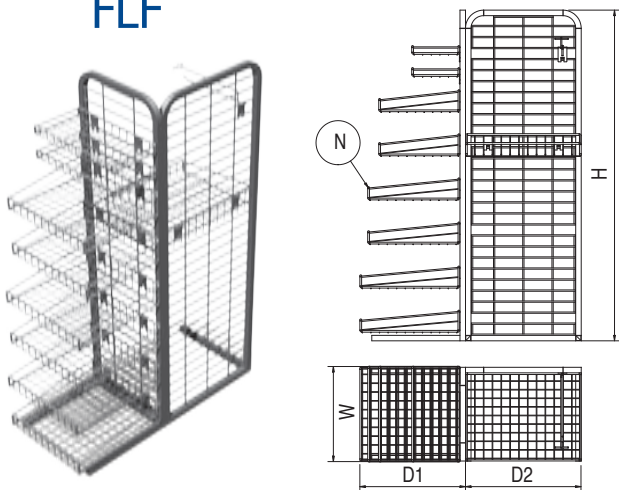

FLM

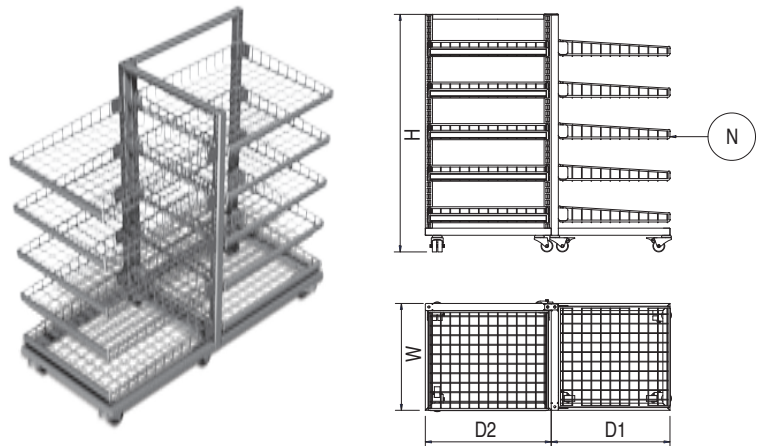



ES

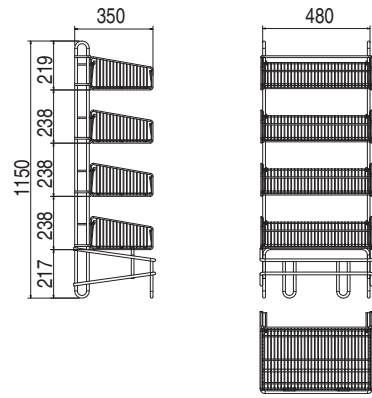
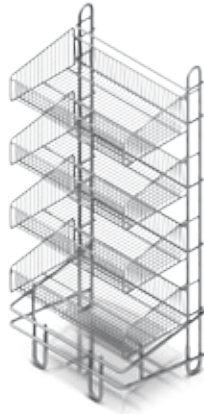

PA

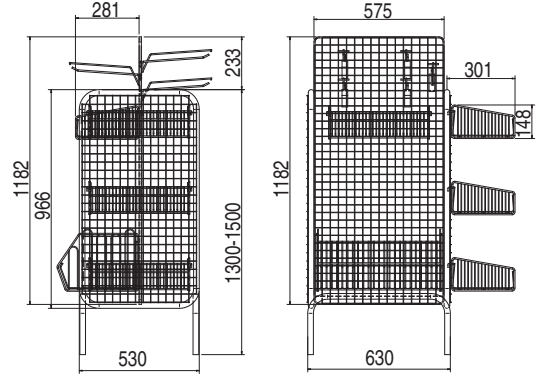

LMD

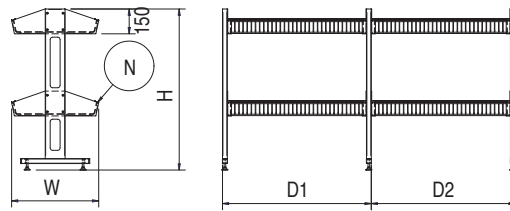

19

Mod.	W(mm)	D(mm)	D1(mm)	D2(mm)	H(mm)	N max
FLF	425	-	480	525	1500	8
FLM	450	-	500	530	1000	5
FM	450	500	-	-	850	4
FM	500	500	-	-	1000	5
FR	1000	680	-	-	850	4
LMD	530	-	900	870	975	2

FM

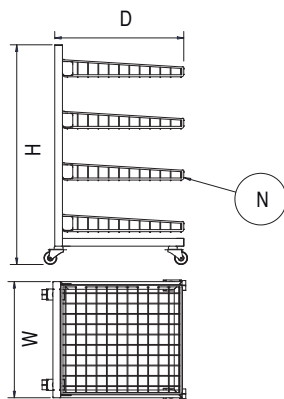

FR

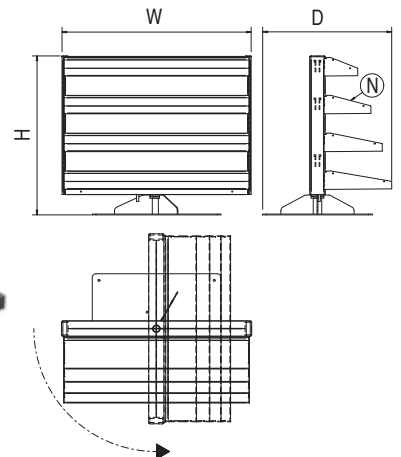

Check-out counter lines



45100 ROVIGO - Italy
Via A. Grandi, 24
Tel. +39 0425 363666
Fax +39 0425 363600

Internet: www.intrac.it
e-mail: info@intrac.it



ISO 9001:2000
1000324



ISO 14001



L'INTRAC Spa, la cui politica è quella di un continuo perfezionamento, si riserva il diritto di apportare in qualunque momento modifiche ai dati contenuti in questa pubblicazione senza obbligo alcuno di avviso preventivo. • INTRAC S.p.a., in line with its policy of constant improvement, reserves the right to modify the data included in this catalogue at any time and without notice. • Die Firma INTRAC Spa, deren Politik eine stetige Verbesserung ihrer Produkte ist, behält sich das Recht vor, in irgendeinem Augenblick Inhaltsänderungen, ohne vorherige Benachrichtigungspflicht, in dem vorliegenden Katalog vorzunehmen. • INTRAC Spa, dont la politique est celle d'un perfectionnement continu, se réserve le droit d'apporter des modifications n'importe quand aux données contenues dans ce catalogue, sans aucune obligation de préavis de notre part. • A INTRAC Spa, cuja política de continuo aperfeiçoamento, reserva-se o direito de alterar em qualquer momento, a modificação de dados contidos nesta publicação, sem obrigação alguma de pré aviso. • INTRAC S.p.a., según su política de continuo refinamiento, se reserva el derecho de modificar los datos incluidos en este catálogo en cualquier momento y sin previo aviso. • Фирма INTRAC SPA, политикой которой является постоянное совершенство, оставляет за собой право изменить все данные этого каталога в любой момент, без предварительного уведомления.